

# Internal Roll-a-Finish® tools

## SRMR/SRMB series

*Our premier line of internal Roll-a-Finish® tools, designed to suit all applications. Ideal for applications where tool length is restricted by tool changers, turrets, etc.*



### Offered in *three styles:*

- Through-hole style with no-helix cage (machine-feeding) as standard.
- Through-hole style with helix cage (self-feeding), made to order.
- Bottoming-style for blind hole, with no-helix cage (machine-feeding) as standard.



### ... with up to *three work lengths:*

- SRMR (B)
- SRMR (B)+50mm
- SRMR (B)+100mm
- Longer lengths available on request.

### ... and *available from stock:*

- for hole sizes from 4,00 to 50,00 mm (.157 to 1.968 inches).
- Tools are adjustable in increments of .002mm (.0001 inch).

## Standard tool specifications

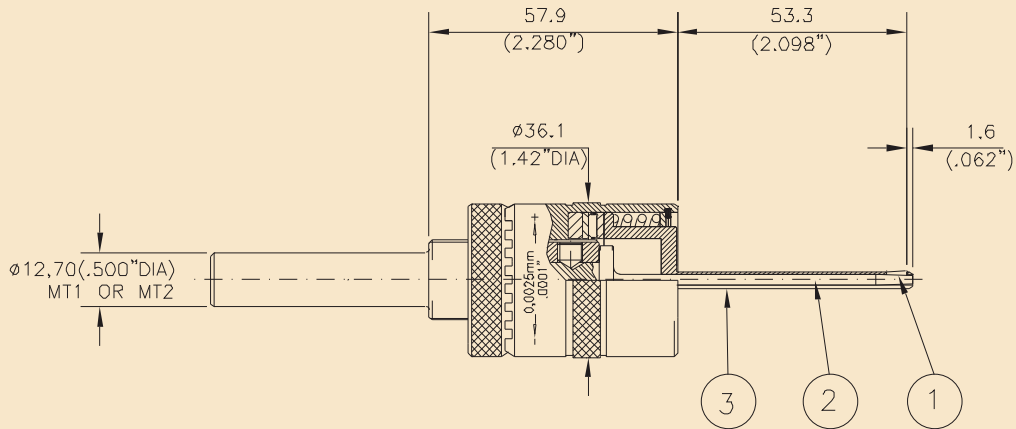

**MAIN SPARES**

1. ROLLS (3/TOOL)
2. MANDREL CONE
3. CAGE

**SRMR SERIES ROLL-A-FINISH® TOOLS**

**4,0 to 5,75mm (.157" to .226")**

DIAMETER RANGE				TOOL NUMBER		
MIN		MAX		THRO-HOLE (No Helix)	BOTTOMING (No Helix)	SELF-FEED OPTION (1½° Helix)
mm	Inches	mm	Inches			
3,97	.156	4,25	.167	SRMR 4	-	-
4,22	.166	4,50	.177	SRMR 4,25	-	-
4,47	.176	4,75	.187	SRMR 4,50	-	-
4,72	.186	5,00	.197	SRMR 4,75	-	-
4,97	.196	5,25	.207	SRMR 5	-	Thro-Hole only
5,22	.206	5,50	.217	SRMR 5,25	-	Thro-Hole only
5,47	.215	5,75	.226	SRMR 5,50	-	Thro-Hole only
5,72	.225	6,00	.236	SRMR 5,75	-	Thro-Hole only

*Tools other than shown above are available upon request.*

# Standard tool specifications

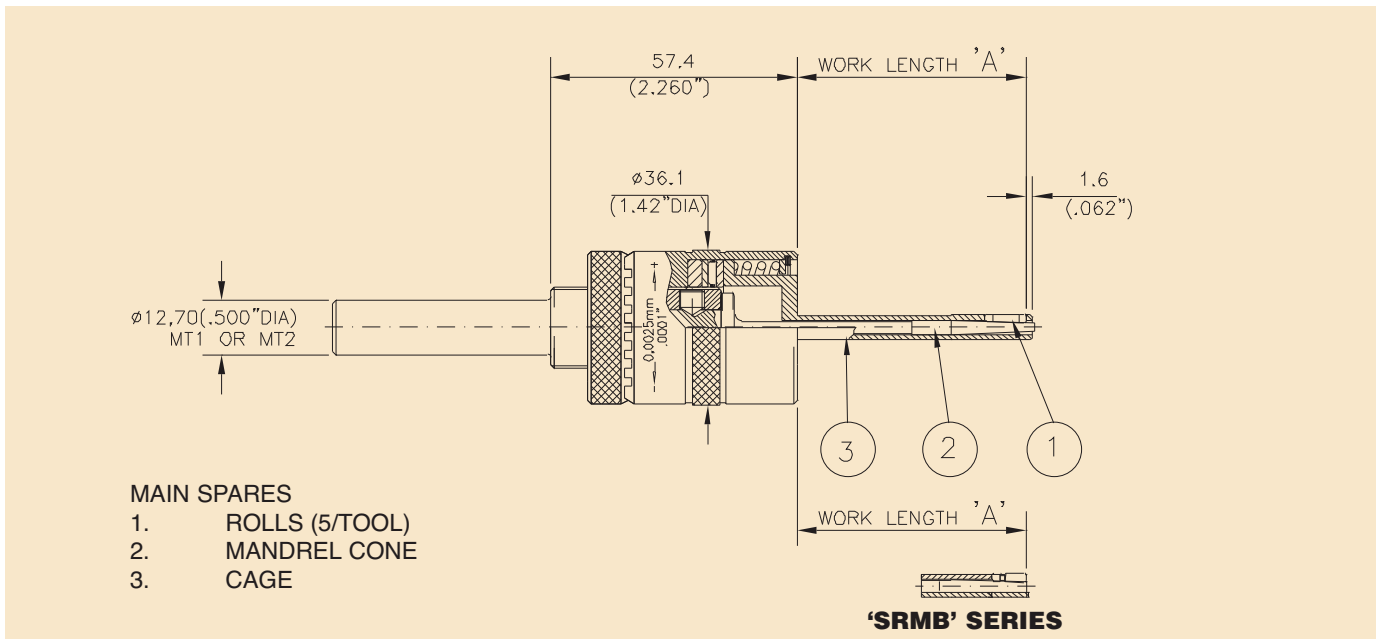

SRMR/SRMB SERIES ROLL-A-FINISH® TOOLS

6,0 to 12,5mm (.236" to .492")

DIAMETER RANGE				TOOL NUMBER			
MIN		MAX		Standard Length 'A' = 53.3mm (2.098")		Extended Length 'A' = 104.1mm (4.098")	
mm	Inches	mm	Inches	THRO-HOLE (No Helix)	BOTTOMING (No Helix)	THRO-HOLE (No Helix)	BOTTOMING (No Helix)
5,95	.234	6,50	.256	SRMR 6	SRMB 6	SRMR 6 + 50	SRMB 6 + 50
6,45	.254	7,00	.276	SRMR 6,50	SRMB 6,50	SRMR 6,50 + 50	SRMB 6,50 + 50
6,95	.274	7,50	.295	SRMR 7	SRMB 7	SRMR 7 + 50	SRMB 7 + 50
7,45	.293	8,00	.315	SRMR 7,50	SRMB 7,50	SRMR 7,50 + 50	SRMB 7,50 + 50
7,95	.313	8,50	.335	SRMR 8	SRMB 8	SRMR 8 + 50	SRMB 8 + 50
8,45	.333	9,00	.354	SRMR 8,50	SRMB 8,50	SRMR 8,50 + 50	SRMB 8,50 + 50
8,95	.352	9,50	.374	SRMR 9	SRMB 9	SRMR 9 + 50	SRMB 9 + 50
9,45	.372	10,00	.394	SRMR 9,50	SRMB 9,50	SRMR 9,50 + 50	SRMB 9,50 + 50
9,95	.392	10,50	.413	SRMR 10	SRMB 10	SRMR 10 + 50	SRMB 10 + 50
10,45	.411	11,00	.433	SRMR 10,50	SRMB 10,50	SRMR 10,50 + 50	SRMB 10,50 + 50

Optional Self-Feeding 1 1/2° Helix Style Tools are Available for all Sizes, Styles and Lengths in this Range.

DIAMETER RANGE				TOOL NUMBER					
MIN		MAX		Standard Length 'A' = 66.3mm (2.610")		Extended Length 'A' = 117.1mm (4.610")		Extra Length 'A' = 167.9mm (6.610")	
mm	Inches	mm	Inches	THRO-HOLE (No Helix)	BOTTOMING (No Helix)	THRO-HOLE (No Helix)	BOTTOMING (No Helix)	THRO-HOLE (No Helix)	BOTTOMING (No Helix)
10,95	.431	11,50	.453	SRMR 11	SRMB 11	SRMR 11 + 50	SRMB 11 + 50	SRMR 11 + 100	SRMB 11 + 100
11,45	.451	12,00	.472	SRMR 11,50	SRMB 11,50	SRMR 11,50 + 50	SRMB 11,50 + 50	SRMR 11,50 + 100	SRMB 11,50 + 100
11,95	.470	12,50	.492	SRMR 12	SRMB 12	SRMR 12 + 50	SRMB 12 + 50	SRMR 12 + 100	SRMB 12 + 100
12,45	.490	13,00	.512	SRMR 12,50	SRMB 12,50	SRMR 12,50 + 50	SRMB 12,50 + 50	SRMR 12,50 + 100	SRMB 12,50 + 100

Optional Self-Feeding 1 1/2° Helix Style Tools are Available for all Sizes, Styles and Lengths in this Range

When ordering Blind Bore Tools please state actual size to be burnished.  
Tools other than shown above are available upon request.

# Standard tool specifications

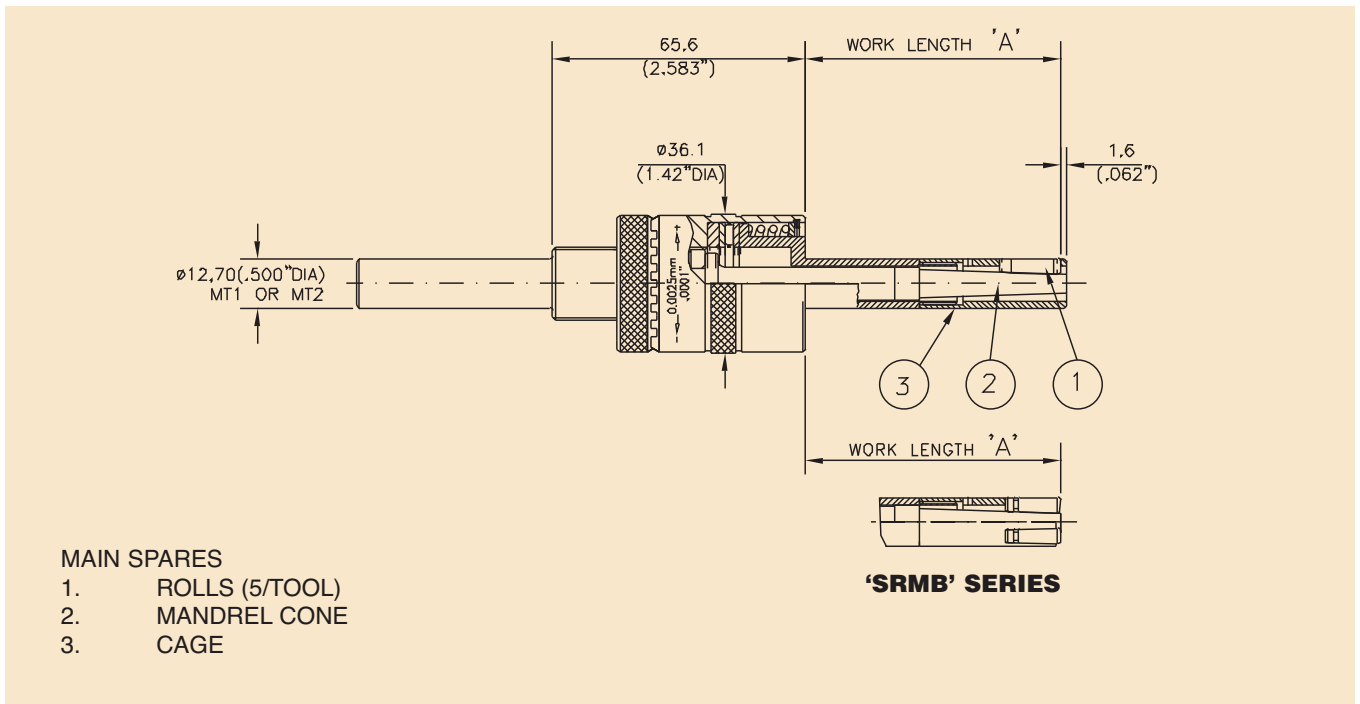

**SRMR/SRMB SERIES ROLL-A-FINISH® TOOLS**

**13,0 to 24,0mm (.512" to .945")**

DIAMETER RANGE				TOOL NUMBER					
MIN		MAX		Standard Length 'A' = 66.3mm (2.610")		Extended Length 'A' = 117.1mm (4.610")		Extra Length 'A' = 167.9mm (6.610")	
mm	Inches	mm	Inches	THRO-HOLE (No Helix)	BOTTOMING (No Helix)	THRO-HOLE (No Helix)	BOTTOMING (No Helix)	THRO-HOLE (No Helix)	BOTTOMING (No Helix)
12,90	.508	14,00	.551	SRMR 13	SRMB 13	SRMR 13 + 50	SRMB 13 + 50	SRMR 13 + 100	SRMB 13 + 100
13,90	.547	15,00	.591	SRMR 14	SRMB 14	SRMR 14 + 50	SRMB 14 + 50	SRMR 14 + 100	SRMB 14 + 100
14,90	.587	16,00	.630	SRMR 15	SRMB 15	SRMR 15 + 50	SRMB 15 + 50	SRMR 15 + 100	SRMB 15 + 100
15,90	.626	17,00	.669	SRMR 16	SRMB 16	SRMR 16 + 50	SRMB 16 + 50	SRMR 16 + 100	SRMB 16 + 100
16,90	.665	18,00	.709	SRMR 17	SRMB 17	SRMR 17 + 50	SRMB 17 + 50	SRMR 17 + 100	SRMB 17 + 100
17,90	.705	19,00	.748	SRMR 18	SRMB 18	SRMR 18 + 50	SRMB 18 + 50	SRMR 18 + 100	SRMB 18 + 100
18,90	.744	20,00	.787	SRMR 19	SRMB 19	SRMR 19 + 50	SRMB 19 + 50	SRMR 19 + 100	SRMB 19 + 100
19,90	.783	21,00	.827	SRMR 20	SRMB 20	SRMR 20 + 50	SRMB 20 + 50	SRMR 20 + 100	SRMB 20 + 100
20,90	.823	22,00	.866	SRMR 21	SRMB 21	SRMR 21 + 50	SRMB 21 + 50	SRMR 21 + 100	SRMB 21 + 100
21,90	.862	23,00	.906	SRMR 22	SRMB 22	SRMR 22 + 50	SRMB 22 + 50	SRMR 22 + 100	SRMB 22 + 100
22,90	.902	24,00	.945	SRMR23	SRMB 23	SRMR 23 + 50	SRMB 23 + 50	SRMR 23 + 100	SRMB 23 + 100
23,90	.941	25,00	.984	SRMR 24	SRMB 24	SRMR 24 + 50	SRMB 24 + 50	SRMR 24 + 100	SRMB 24 + 100

Optional Self-Feeding 1/2° Helix Style Tools are Available for all Sizes, Styles and Lengths in this Range

*When ordering Blind Bore Tools please state actual size to be burnished.  
Tools other than shown above are available upon request.*

# Standard tool specifications

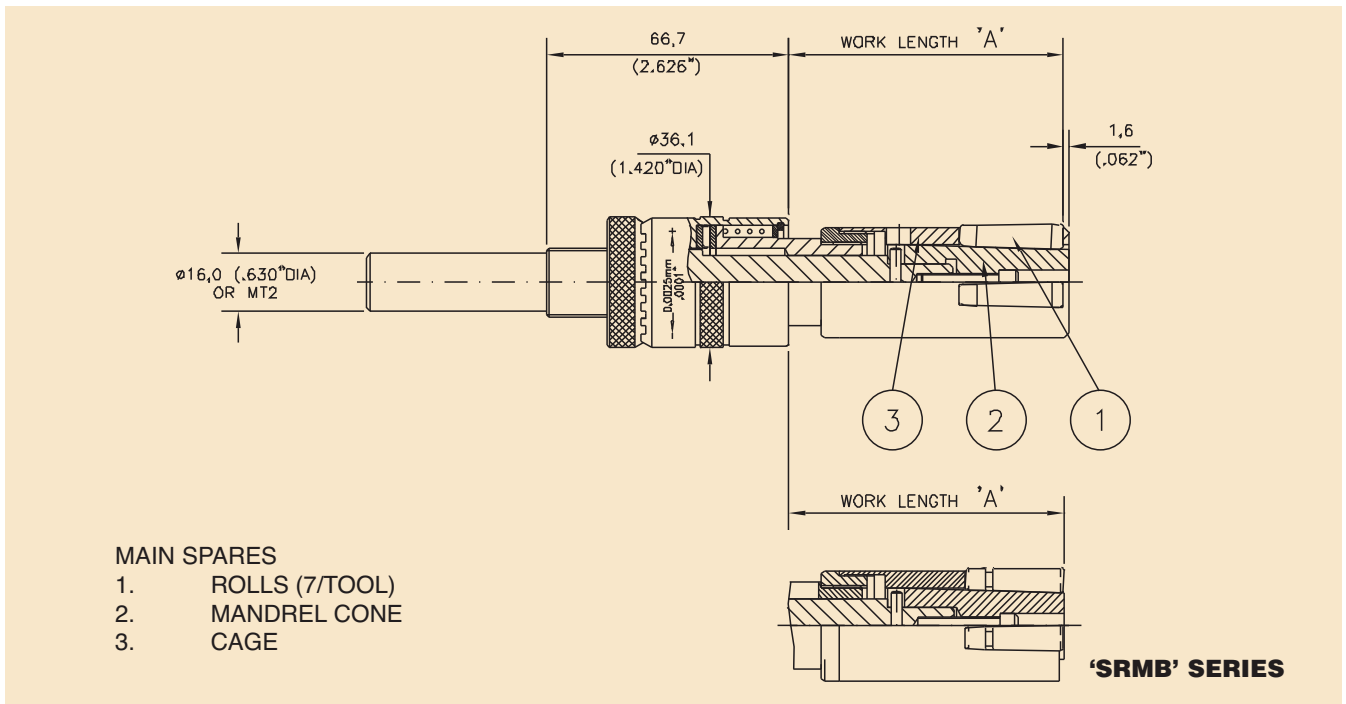

**SRMR/SRMB SERIES ROLL-A-FINISH® TOOLS**

**25,0 to 50,0mm (.984" to 1.969")**

DIAMETER RANGE				TOOL NUMBER					
MIN		MAX		Standard Length 'A' = 75,7mm (2.980")		Extended Length 'A' = 126,5mm (4.980")		Extra Length 'A' = 177,3mm (6.980")	
mm	Inches	mm	Inches	THRO-HOLE (No Helix)	BOTTOMING (No Helix)	THRO-HOLE (No Helix)	BOTTOMING (No Helix)	THRO-HOLE (No Helix)	BOTTOMING (No Helix)
24,90	.980	26,00	1.024	SRMR 25	SRMB 25	SRMR 25 + 50	SRMB 25 + 50	SRMR 25 + 100	SRMB 25 + 100
25,90	1.020	27,00	1.063	SRMR 26	SRMB 26	SRMR 26 + 50	SRMB 26 + 50	SRMR 26 + 100	SRMB 26 + 100
26,90	1.059	28,00	1.102	SRMR 27	SRMB 27	SRMR 27 + 50	SRMB 27 + 50	SRMR 27 + 100	SRMB 27 + 100
27,90	1.098	29,00	1.142	SRMR 28	SRMB 28	SRMR 28 + 50	SRMB 28 + 50	SRMR 28 + 100	SRMB 28 + 100
28,90	1.138	30,00	1.181	SRMR 29	SRMB 29	SRMR 29 + 50	SRMB 29 + 50	SRMR 29 + 100	SRMB 29 + 100
29,90	1.177	31,00	1.220	SRMR 30	SRMB 30	SRMR 30 + 50	SRMB 30 + 50	SRMR 30 + 100	SRMB 30 + 100
30,90	1.217	32,00	1.260	SRMR 31	SRMB 31	SRMR 31 + 50	SRMB 31 + 50	SRMR 31 + 100	SRMB 31 + 100
31,90	1.256	33,00	1.300	SRMR 32	SRMB 32	SRMR 32 + 50	SRMB 32 + 50	SRMR 32 + 100	SRMB 32 + 100
32,90	1.295	34,00	1.339	SRMR 33	SRMB 33	SRMR 33 + 50	SRMB 33 + 50	SRMR 33 + 100	SRMB 33 + 100
33,90	1.335	35,00	1.378	SRMR 34	SRMB 34	SRMR 34 + 50	SRMB 34 + 50	SRMR 34 + 100	SRMB 34 + 100
34,90	1.374	36,00	1.417	SRMR 35	SRMB 35	SRMR 35 + 50	SRMB 35 + 50	SRMR 35 + 100	SRMB 35 + 100
35,90	1.413	37,00	1.457	SRMR 36	SRMB 36	SRMR 36 + 50	SRMB 36 + 50	SRMR 36 + 100	SRMB 36 + 100
36,90	1.453	38,00	1.496	SRMR 37	SRMB 37				
37,90	1.492	39,00	1.535	SRMR 38	SRMB 38				
38,90	1.531	40,00	1.574	SRMR 39	SRMB 39				
39,90	1.571	41,00	1.614	SRMR 40	SRMB 40				
40,90	1.610	42,00	1.654	SRMR 41	SRMB 41				
41,90	1.649	43,00	1.693	SRMR 42	SRMB 42				
42,90	1.689	44,00	1.732	SRMR 43	SRMB 43				
43,90	1.728	45,00	1.772	SRMR 44	SRMB 44				
44,90	1.768	46,00	1.811	SRMR 45	SRMB 45				
45,90	1.807	47,00	1.850	SRMR 46	SRMB 46				
46,90	1.846	48,00	1.890	SRMR 47	SRMB 47				
47,90	1.886	49,00	1.929	SRMR 48	SRMB 48				
48,90	1.925	50,00	1.968	SRMR 49	SRMB 49				
49,90	1.964	51,00	2.008	SRMR 50	SRMB 50				

**ON COMPONENT BORES MORE THAN 36MM, INFINITE LENGTHS CAN BE BURNISHED BY ADDING SHANK ADAPTORS**

Optional Self-Feeding 1 1/2° Helix Style Tools are Available for all Sizes, Styles and Lengths in this Range

*When ordering Blind Bore Tools please state actual size to be burnished.  
Tools other than shown above are available upon request.*

# Standard tool specifications

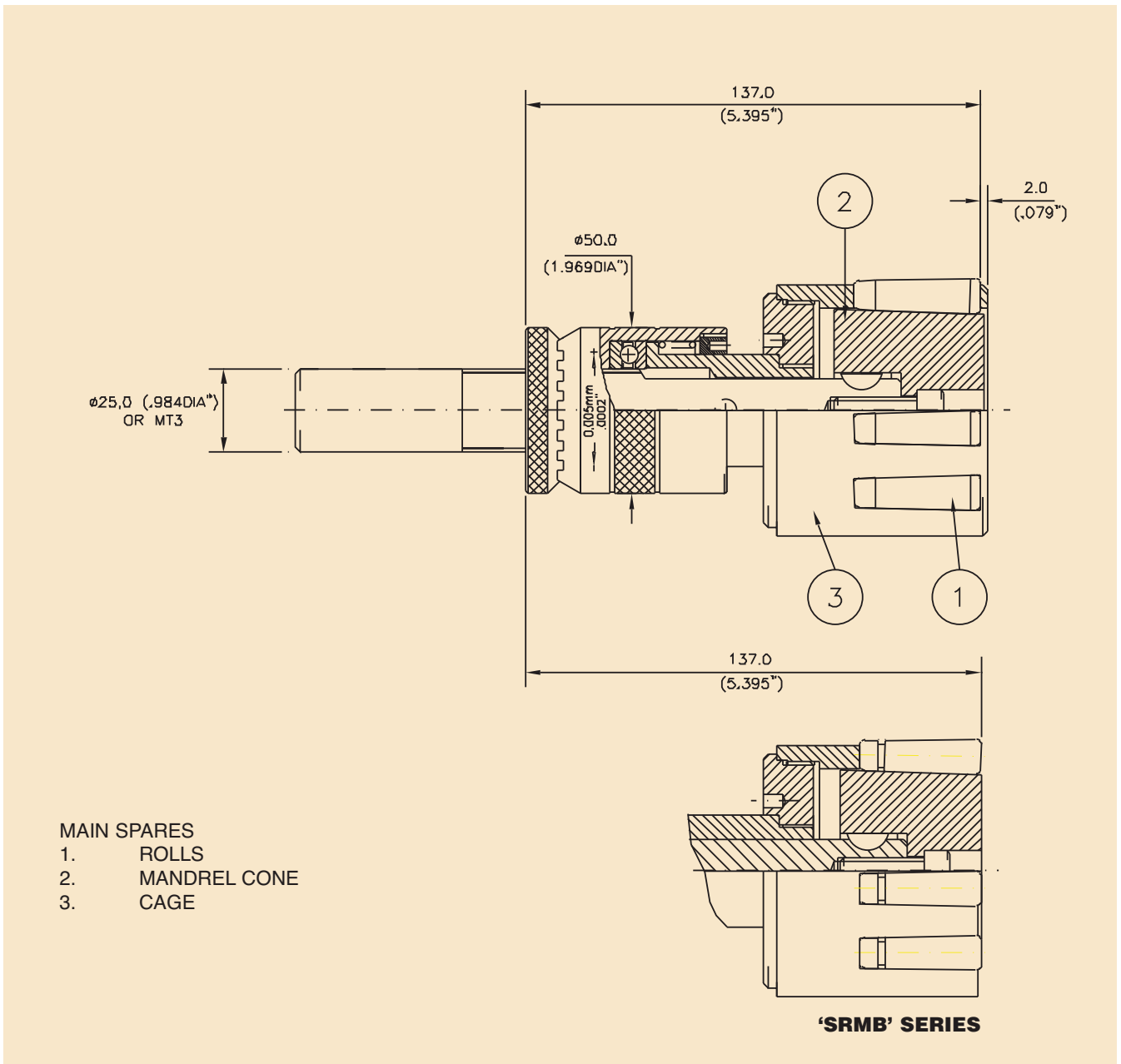

**SRMR/SRMB** SERIES ROLL-A-FINISH® TOOLS

**51,0 to 89,0mm (2.008" to 3.504")**

SEE NEXT PAGE FOR CHART

*When ordering Blind Bore Tools please state actual size to be burnished.  
Tools other than shown above are available upon request.*

# Standard tool specifications

SRMR/SRMB SERIES ROLL-A-FINISH® TOOLS

51,0 to 89,0mm (2.008" to 3.504")

DIAMETER RANGE				TOOL NUMBER	
MIN		MAX		(UNLIMITED WORKING LENGTH USING SHANK EXTENSIONS)	
mm	Inches	mm	Inches	THRO-HOLE (No Helix)	BOTTOMING (No Helix)
50,90	2.004	52,00	2.047	SRMR 51	SRMB 51
51,90	2.043	53,00	2.087	SRMR 52	SRMB 52
52,90	2.083	54,00	2.126	SRMR 53	SRMB 53
53,90	2.122	55,00	2.165	SRMR 54	SRMB 54
54,90	2.161	56,00	2.205	SRMR 55	SRMB 55
55,90	2.201	57,00	2.244	SRMR 56	SRMB 56
56,90	2.240	58,00	2.283	SRMR 57	SRMB 57
57,90	2.280	59,00	2.323	SRMR 58	SRMB 58
58,90	2.319	60,00	2.362	SRMR 59	SRMB 59
59,90	2.358	61,00	2.402	SRMR 60	SRMB 60
60,90	2.398	62,00	2.441	SRMR 61	SRMB 61
61,90	2.437	63,00	2.480	SRMR 62	SRMB 62
62,90	2.476	64,00	2.520	SRMR 63	SRMB 63
63,90	2.516	65,00	2.559	SRMR 64	SRMB 64
64,90	2.555	66,00	2.598	SRMR 65	SRMB 65
65,90	2.594	67,00	2.638	SRMR 66	SRMB 66
66,90	2.634	68,00	2.677	SRMR 67	SRMB 67
67,90	2.673	69,00	2.717	SRMR 68	SRMB 68
68,90	2.713	70,00	2.756	SRMR 69	SRMB 69
69,90	2.752	71,00	2.795	SRMR 70	SRMB 70
70,90	2.791	72,00	2.835	SRMR 71	SRMB 71
71,90	2.831	73,00	2.874	SRMR 72	SRMB 72
72,90	2.870	74,00	2.913	SRMR 73	SRMB 73
73,90	2.909	75,00	2.953	SRMR 74	SRMR 74
74,90	2.949	76,00	2.992	SRMR 75	SRMB 75
75,90	2.988	77,00	3.031	SRMR 76	SRMB 76
76,90	3.028	78,00	3.071	SRMR 77	SRMB 77
77,90	3.067	79,00	3.110	SRMR 78	SRMB 78
78,90	3.106	80,00	3.150	SRMR 79	SRMB 79
79,90	3.146	81,00	3.189	SRMR 80	SRMB 80
80,90	3.185	82,00	3.228	SRMR 81	SRMB 81
81,90	3.224	83,00	3.268	SRMR 82	SRMB 82
82,90	3.264	84,00	3.307	SRMR 83	SRMB 83
83,90	3.303	85,00	3.346	SRMR 84	SRMB 84
84,90	3.343	86,00	3.386	SRMR 85	SRMB 85
85,90	3.382	87,00	3.425	SRMR 86	SRMB 86
86,90	3.421	88,00	3.465	SRMR 87	SRMB 87
87,90	3.461	89,00	3.504	SRMR 88	SRMB 88
88,90	3.500	90,00	3.543	SRMR 89	SRMB 89

Optional Self-Feeding 1½° Helix Style Tools are Available for all Sizes and Styles in this Range

# Standard tool specifications

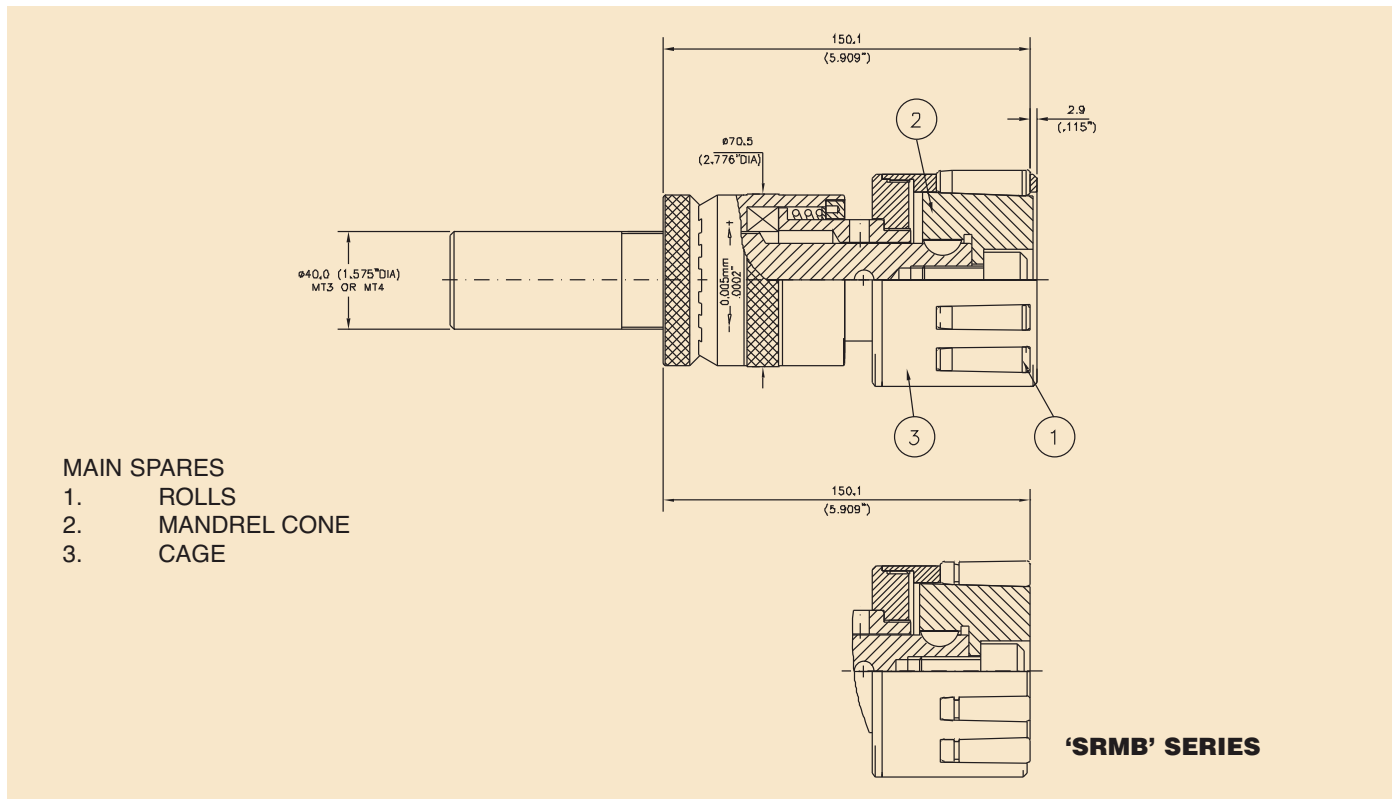

SRMR/SRMB SERIES ROLL-A-FINISH® TOOLS

90,0 to 177,0 mm (3.543" to 6.969")

DIAMETER RANGE				TOOL NUMBER	
MIN		MAX		(UNLIMITED WORKING LENGTH USING SHANK EXTENSIONS)	
mm	Inches	mm	Inches	THRO-HOLE (No Helix)	BOTTOMING (No Helix)
89,90	3.539	91,00	3.583	SRMR 90	SRMB 90
90,90	3.579	92,00	3.622	SRMR 91	SRMB 91
91,90	3.618	93,00	3.661	SRMR 92	SRMB 92
92,90	3.657	94,00	3.701	SRMR 93	SRMB 93
93,90	3.697	95,00	3.740	SRMR 94	SRMB 94
94,90	3.736	96,00	3.780	SRMR 95	SRMB 95
95,90	3.776	97,00	3.819	SRMR 96	SRMB 96
96,90	3.815	98,00	3.858	SRMR 97	SRMB 97
97,90	3.854	99,00	3.898	SRMR 98	SRMB 98
98,90	3.894	100,00	3.937	SRMR 99	SRMB 99
99,90	3.933	101,00	3.976	SRMR 100	SRMB 100
100,90	3.972	102,00	4.016	SRMR 101	SRMB 101
101,90	4.012	103,00	4.055	SRMR 102	SRMB 102
102,90	4.052	104,00	4.094	SRMR 103	SRMB 103
103,90	4.091	105,00	4.134	SRMR 104	SRMB 104
104,90	4.130	106,00	4.173	SRMR 105	SRMB 105
105,90	4.169	107,00	4.213	SRMR 106	SRMB 106
106,90	4.209	108,00	4.252	SRMR 107	SRMB 107
107,90	4.248	109,00	4.291	SRMR 108	SRMB 108
108,90	4.287	110,00	4.331	SRMR 109	SRMB 109
109,90	4.327	111,00	4.370	SRMR 110	SRMB 110
110,90	4.366	112,00	4.409	SRMR 111	SRMB 111
111,90	4.406	113,00	4.449	SRMR 112	SRMB 112
112,90	4.445	114,00	4.488	SRMR 113	SRMB 113

Optional Self-Feeding 1 1/2° Helix Style Tools are Available for all Sizes and Styles in this Range

*When ordering Blind Bore Tools please state actual size to be burnished.  
Tools other than shown above are available upon request.*



DIAMETER RANGE				TOOL NUMBER	
MIN		MAX		(UNLIMITED WORKING LENGTH USING SHANK EXTENSIONS)	
mm	Inches	mm	Inches	THRO-HOLE (No Helix)	BOTTOMING (No Helix)
113,90	4.484	115,00	4.528	SRMR 114	SRMB 114
114,90	4.524	116,00	4.567	SRMR 115	SRMB 115
115,90	4.563	117,00	4.606	SRMR 116	SRMB 116
116,90	4.602	118,00	4.646	SRMR 117	SRMB 117
117,90	4.642	119,00	4.685	SRMR 118	SRMB 118
118,90	4.681	120,00	4.724	SRMR 119	SRMB 119
119,90	4.720	121,00	4.764	SRMR 120	SRMB 120
120,90	4.760	122,00	4.803	SRMR 121	SRMB 121
121,90	4.799	123,00	4.843	SRMR 122	SRMB 122
122,90	4.839	124,00	4.882	SRMR 123	SRMB 123
123,90	4.878	125,00	4.921	SRMR 124	SRMB 124
124,90	4.917	126,00	4.961	SRMR 125	SRMB 125
125,90	4.957	127,00	5.000	SRMR 126	SRMB 126
126,90	4.996	128,00	5.039	SRMR 127	SRMB 127
127,90	5.035	129,00	5.079	SRMR 128	SRMB 128
128,90	5.075	130,00	5.118	SRMR 129	SRMB 129
129,90	5.114	131,00	5.157	SRMR 130	SRMB 130
130,90	5.154	132,00	5.197	SRMR 131	SRMB 131
131,90	5.193	133,00	5.236	SRMR 132	SRMB 132
132,90	5.232	134,00	5.276	SRMR 133	SRMB 133
133,90	5.272	135,00	5.315	SRMR 134	SRMB 134
134,90	5.311	136,00	5.354	SRMR 135	SRMB 135
135,90	5.350	137,00	5.394	SRMR 136	SRMB 136
136,90	5.390	138,00	5.433	SRMR 137	SRMB 137
137,90	5.429	139,00	5.472	SRMR 138	SRMB 138
138,90	5.469	140,00	5.512	SRMR 139	SRMB 139
139,90	5.508	141,00	5.551	SRMR 140	SRMB 140
140,90	5.547	142,00	5.591	SRMR 141	SRMB 141
141,90	5.587	143,00	5.630	SRMR 142	SRMB 142
142,90	5.626	144,00	5.669	SRMR 143	SRMB 143
143,90	5.665	145,00	5.709	SRMR 144	SRMB 144
144,90	5.705	146,00	5.748	SRMR 145	SRMB 145
145,90	5.744	147,00	5.787	SRMR 146	SRMB 146
146,90	5.783	148,00	5.827	SRMR 147	SRMB 147
147,90	5.823	149,00	5.866	SRMR 148	SRMB 148
148,90	5.862	150,00	5.906	SRMR 149	SRMB 149
149,90	5.902	151,00	5.945	SRMR 150	SRMB 150
150,90	5.941	152,00	5.984	SRMR 151	SRMB 151
151,90	5.980	153,00	6.024	SRMR 152	SRMB 152
152,90	6.020	154,00	6.063	SRMR 153	SRMB 153
153,90	6.059	155,00	6.102	SRMR 154	SRMB 154
154,90	6.098	156,00	6.142	SRMR 155	SRMB 155
155,90	6.138	157,00	6.181	SRMR 156	SRMB 156
156,90	6.177	158,00	6.220	SRMR 157	SRMB 157
157,90	6.217	159,00	6.260	SRMR 158	SRMB 158
158,90	6.256	160,00	6.299	SRMR 159	SRMB 159
159,90	6.295	161,00	6.339	SRMR 160	SRMB 160
160,90	6.335	162,00	6.378	SRMR 161	SRMB 161
161,90	6.374	163,00	6.417	SRMR 162	SRMB 162
162,90	6.413	164,00	6.457	SRMR 163	SRMB 163
163,90	6.453	165,00	6.496	SRMR 164	SRMB 164
164,90	6.492	166,00	6.535	SRMR 165	SRMB 165
165,90	6.531	167,00	6.575	SRMR 166	SRMB 166
166,90	6.571	168,00	6.614	SRMR 167	SRMB 167
167,90	6.610	169,00	6.654	SRMR 168	SRMB 168
168,90	6.650	170,00	6.693	SRMR 169	SRMB 169
169,90	6.690	171,00	6.732	SRMR 170	SRMB 170
170,90	6.728	172,00	6.772	SRMR 171	SRMB 171
171,90	6.768	173,00	6.811	SRMR 172	SRMB 172
172,90	6.807	174,00	6.850	SRMR 173	SRMB 173
173,90	6.846	175,00	6.890	SRMR 174	SRMB 174
174,90	6.886	176,00	6.929	SRMR 175	SRMB 175
175,90	6.925	177,00	6.969	SRMR 176	SRMB 176
176,90	6.965	178,00	7.008	SRMR 177	SRMB 177

Optional Self-Feeding 1 1/2° Helix Style Tools are Available for all Sizes and Styles in this Range

**ROLLS**

INTERNAL ROLLER BURNISHING ROLL CHART					
TOOL NUMBER			ROLL NUMBER		QTY / TOOL
(FROM	-	TO)	THRO-HOLE	BOTTOMING	
SRM 4	-	4,75	RR137	-	3
SRM 5	-	5,75	SR187	-	3
SRMR 6	-	7,50	R250	B250	5
SRMR 8	-	9	R312	B312	5
SRMR 9,50	-	10,50	R375	B375	5
SRMR 11	-	12,50	R437	B437	5
SRMR 13	-	17	R500	B500	5
SRMR 18	-	24	R750	B750	5
SRMR 25	-	29	R750	B750	7
SRMR 30	-	35	R875	B875	7
SRMR 36	-	41	R1125	B1125	7
SRMR 42	-	50	R1625	B1625	7
SRMR 51	-	69	R1625	B1625	9
SRMR 70	-	89	R1625	B1625	11
SRMR 90	-	110	R1625	B1625	13
SRMR 111	-	135	R1625	B1625	15
SRMR 136	-	155	R1625	B1625	17
SRMR 156	-	177	R1625	B1625	19