

Boring-bar style

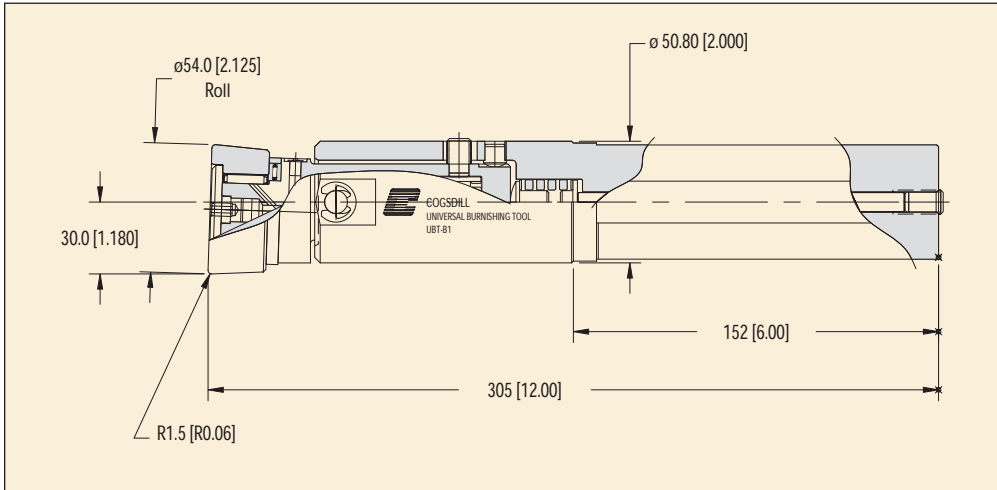

UBT-B1



FOR BURNISHING
OUTSIDE DIAMETERS,
FACES, AND LARGE INSIDE
DIAMETERS (IDS GREATER
THAN 70mm/2.75 in.)

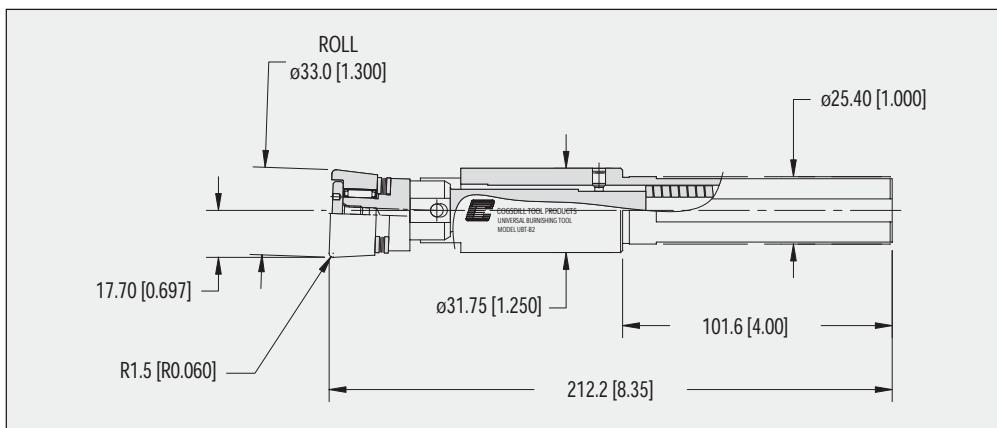

UBT-B2



A SMALLER VERSION
OF THE UBT-B1

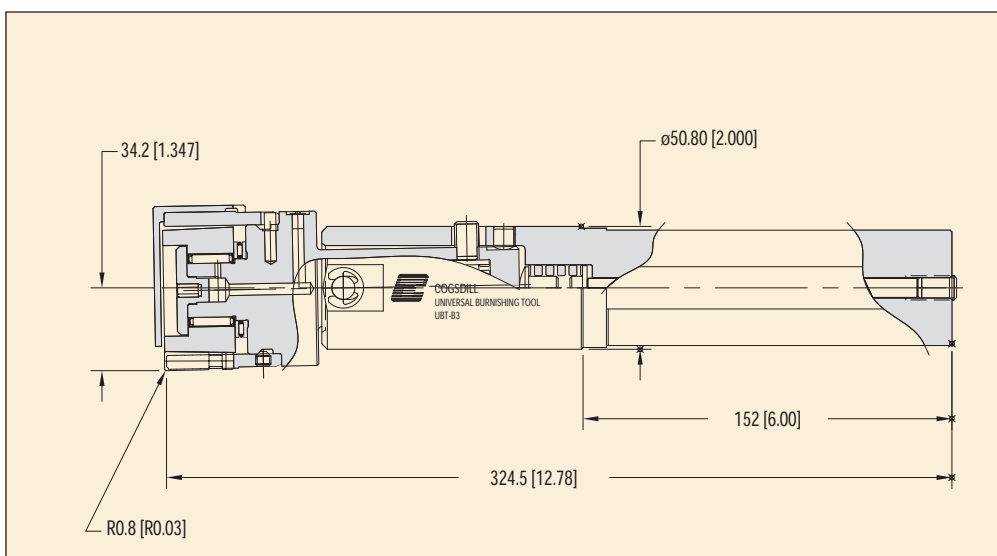

UBT-B3



FOR USE IN SMALLER INSIDE
DIAMETERS (IDS GREATER
THAN 70MM/2.75 IN.) OR ON
LARGE OUTSIDE DIAMETERS
(GREATER THAN
100mm/4.00in.)